

# 050

## 頂部法蘭油壓轉角缸

## 050 HYDRAULIC SWING CLAMP

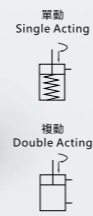

### 產品特性

當空間非常小時，050系列具備最小的安裝高度，但需預留孔放置轉角缸；缸體的主結構可隱藏在工作檯面；安裝簡單，只用三四個螺栓就能固定；對稱法蘭設計使轉角缸採用三點或四點螺體對稱固定。050分為單動式和複動式兩種。複動式特點：夾緊與鬆卸完全靠油路控制，按照換向閥的方向交替來控制轉角缸的夾緊與鬆卸過程。

單動式特點：內部系統化比較簡單，沒有卸載系統，卸載時靠彈簧回力完成鬆卸行程；外部管路的閥門及附件較少，使配套系統比較簡單。單動式可以空載回程。缸體材質合用碳鋼，經滲碳氮化處理，表面硬度高，缸體內面硬度高，耐磨損。

最大操作壓力：250 kgf/cm<sup>2</sup>  
 最小操作壓力：70 kgf/cm<sup>2</sup>  
 作動方式：單動和複動式

### 注意事項

夾緊及放鬆作動速度需適當放緩。  
 特殊壓臂長度及重量不得超過標準壓臂的1.5倍。  
 壓臂旋轉示意圖及安裝拆卸方式，請參見第4頁。

### 訂購標示法 ORDERING INDICATION

示例：050-LD92-90

050	系列 Series	050	
L	轉角方向 Swing direction	右轉R或左轉L	Turn right R or turn left L
D	作動方式 Acting type	S:單動式 D:複動式	S:Single acting D:Double acting
92	型號 Type	22, 52, 92, 121, 202	
90	轉角角度 Swing angle	標準角度 訂做角度	Standard angle 90°(±2°) Order angle 30°(±2°), 45°(±2°), 60°(±2°)

### FEATURES

050 series owns the smallest height for mounting when space is limited, but it is necessary to manufacture a hole for installing swing clamp on fixture plate and the cylinder body can be inserted into the fixture plate. Installing is very simple. You just need 3 or 4 PCS of bolts to fix your swing clamp cylinder. It has the single acting and double acting type. Feature of the doubling acting type: Oil circuits control clamping and unclamping, you can control the clamping and unclamping by changing the direction of the valve.

Feature of the single acting type: The design of the interior system is simple. It is not necessary to design for unclamping. It can return back to original position by spring and the system design is simple because of few accessories. It can return back to position under free load. The material of the cylinder body is carbon steel and treated by nicarbing. The hardness of the outside and inside surface of the cylinder is high and the cylinder is anti-abrasive.

Max. operating pressure: 250 kgf/cm<sup>2</sup>  
 Min. operating pressure: 70 kgf/cm<sup>2</sup>  
 Single acting and double acting

### 剖面圖 Sectional view (複動型)

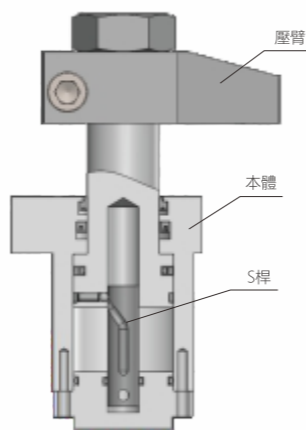

### 050-22/52/121

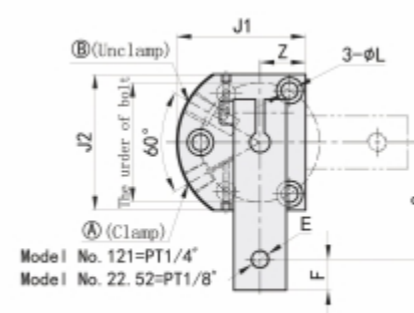

Model No. 121=PT1/4"  
 Model No. 22, 52=PT1/8"

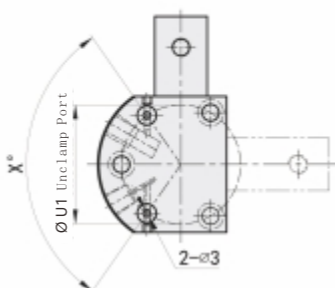
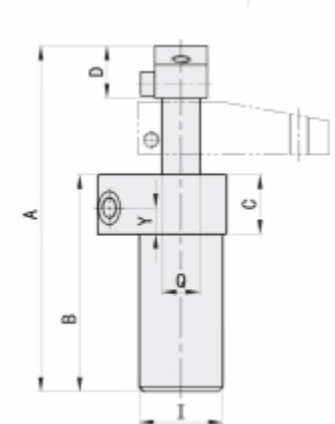

### 050-92/202

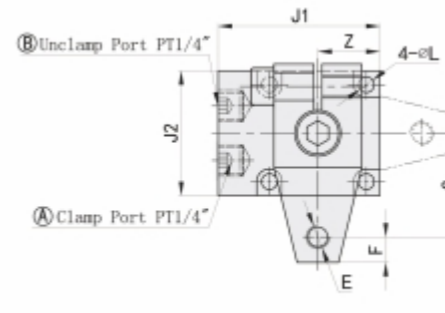

Model No. 92=φ3.3  
 Model No. 202=φ4.0

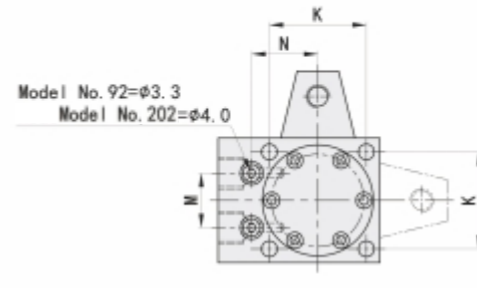
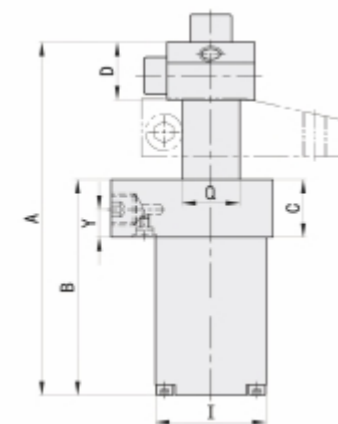

Unit:mm

MODEL ITEM	050-22	050-52	050-92	050-121	050-202
ST:Swing /Clamp	16.5:8.5 /8	22.6:12.6 /10	22.1:10.1 /12	28.4:15.4 /13	27.9:13.9 /14
A:鬆開狀態 Unclamping	118	145	153	171.5	169
B	78	91	93.5	110.9	104
C	25	25	25	25	25
D	16	22	25	30	32
E	M6	M8	M10	M10	M12
F	6	13	11	12	15
G	40	49	45	51	55
I	Φ28	Φ35	Φ48	Φ48	Φ63
J1	47.2	54.1	70.1	66.8	85.1
J2	45	57	54	73	70
K	-	-	42	-	55
L	Φ5.5-Φ9 x6.5D	Φ7-Φ11 x7D	Φ6.8-Φ11 x7D	Φ8.5-Φ14 x9D	Φ8.5-Φ14 x9D
M	-	-	23.6	32	29.2
N	-	-	28.7	-	35.6
Z	15.5	19.1	26.9	25.4	35.1
U1	Φ40	Φ50	-	Φ64	-
X	60°	110°	-	110°	-
Y	11	11	12	12	13
Q	Φ10	Φ16	Φ25	Φ22	Φ32

### 規格參數表 SPECIFICATIONS

型號	理論夾持力(250 kgf/cm <sup>2</sup> ) CLAMPING FORCE AT 250 kgf/cm <sup>2</sup> (kgf)	轉角行程	夾緊行程	總行程	拉入容積	推出容積	拉入受壓面積	推出受壓面積	使用溫度範圍	
MODEL	單動系列 Single acting	複動系列 Double acting	SWING STROKE (mm)	CLAMPING STROKE (mm)	TOTAL STROKE(mm)	CYLINDER CAPACITY CLAMP(cm <sup>3</sup> )	CYLINDER CAPACITY UNCLAMP(cm <sup>3</sup> )	EFFPISTON AREA CLAMP(cm <sup>2</sup> )	EFFPISTON AREA UNCLAMP(cm <sup>2</sup> )	RANGE OF TEMPERATURE(°C)
050-22	173	180	8.5	8	16.5	1.24	2.52	0.75	1.53	-10~+70°C
050-52	380	445	14.6	8	22.6	4.05	8.57	1.79	3.79	-10~+70°C
050-92	710	780	14.1	8	22.1	6.92	17.75	3.13	8.03	-10~+70°C
050-121	970	1060	18.4	10	28.4	12.04	22.81	4.24	8.03	-10~+70°C
050-202	1830	1960	17.9	10	27.9	21.93	44.33	7.86	15.89	-10~+70°C